

# E-Flo<sup>®</sup> DCi Sealed 4-Ball Pumps

3A7828C

EN

*Electric drive piston pumps for high volume paint circulation applications. For professional use only.*

See page 3 for model description and page 33 for maximum working pressure.



## Important Safety Instructions

Read all warnings and instructions in this manual and in the **Related Manuals** before using the equipment. Save all instructions.

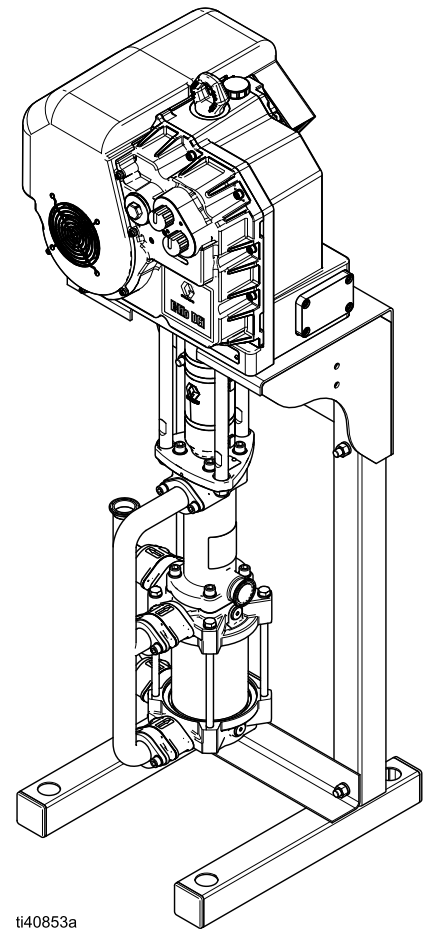

# Contents

<b>Related Manuals</b> .....	<b>2</b>
<b>Models</b> .....	<b>3</b>
<b>Approvals</b> .....	<b>5</b>
<b>Warnings</b> .....	<b>6</b>
<b>Typical Installation</b> .....	<b>8</b>
<b>Installation</b> .....	<b>9</b>
Hazardous Location Cabling and Conduit Requirements .....	9
Power Requirements .....	9
Location Requirements .....	9
Mount the Pump .....	9
Required System Accessories .....	10
Required Fluid Line Accessories .....	10
Grounding .....	10
Connect Supply Wiring .....	11
Install the Fill Cap .....	12
Flush Before Using the Equipment .....	12
<b>Operation</b> .....	<b>13</b>
Pressure Relief Procedure .....	13
Startup .....	13
Shutdown .....	13
<b>Maintenance</b> .....	<b>14</b>
Preventive Maintenance Schedule .....	14
Flushing Procedure .....	14
Change the Oil .....	14
Check Oil Level .....	14
Add Oil .....	15
<b>Troubleshooting</b> .....	<b>16</b>
<b>Repair</b> .....	<b>17</b>
Prepare Equipment for Service .....	17
Disconnect the Pump Lower .....	17
Reconnect the Lower and Motor .....	17

<b>Pump Matrix</b> .....	<b>19</b>
<b>Parts</b> .....	<b>21</b>
<b>Dimensions</b> .....	<b>24</b>
<b>Performance Charts</b> .....	<b>26</b>
<b>Mounting Hole Patterns</b> .....	<b>31</b>
Mounting Bracket Pattern .....	31
Floor Stand Mounting Pattern .....	32
<b>Technical Specifications</b> .....	<b>33</b>
<b>California Proposition 65</b> .....	<b>35</b>
<b>Graco Standard Warranty</b> .....	<b>36</b>

## Related Manuals

Manual No.	Description	Referenced Equipment
3A8352	E-Flo® DCi Motor Installation and Operation Manual	Motor ★
333022	Sealed 4-Ball Lowers, Repair/Parts Manual	Lower ★
3A5348	Sealed 4-Ball Plus Lowers, Repair/Parts Manual	
311619	Pump Mounting Kits Instructions	Pump Mount
3A8471	DCi Link Control Module	Control Module
3A8815	E-Flo DCi Repair Manual	Motor

★ Find your specific motor and lower model in the **Pump Matrix** on page 19.

# Models

The part number for your equipment is printed on the equipment identification label. The pump part number consists of six alphanumeric digits which are based on pump configuration as shown in the following table. The full pump model numbers and associated motor and lower model numbers are listed in the **Pump Matrix** on page 19. For motor and lower repair manuals, see **Related Manuals** on page 2.

First 5 Digits	Sixth Digit			
Basic, Three Phase Motor*	Mounting Type	Horsepower and Lower Size		Lower Type / Fittings
YB904	0: No Stand 1: Stand	3 HP	750CC	Sealed Stainless, Tri-Clamp, Ultralife
YB908		3 HP	750CC	Sealed Stainless, Tri-Clamp Chrome
YD904		3 HP	750CC	Sealed Stainless, Tri-Clamp, Ultralife
YD908		3 HP	750CC	Sealed Stainless, Tri-Clamp Chrome
YB624		3 HP	1000CC	Sealed Stainless, Tri-Clamp, Ultralife
YB628		3 HP	1000CC	Sealed Stainless, Tri-Clamp Chrome
YB629		3 HP	1000CC	Sealed Stainless, Tri-Clamp, Ultralife, SiNi
YD624		3 HP	1000CC	Sealed Stainless, Tri-Clamp, Ultralife
YD628		3 HP	1000CC	Sealed Stainless, Tri-Clamp Chrome
YD629		3 HP	1000CC	Sealed Stainless, Tri-Clamp, Ultralife, SiNi
YB454		3 HP	1500CC	Sealed Stainless, Tri-Clamp, Ultralife
YB458		3 HP	1500CC	Sealed Stainless, Tri-Clamp Chrome
YB459		3 HP	1500CC	Sealed Stainless, Tri-Clamp, Ultralife, SiNi
YD454		3 HP	1500CC	Sealed Stainless, Tri-Clamp, Ultralife
YD458		3 HP	1500CC	Sealed Stainless, Tri-Clamp Chrome
YD459		3 HP	1500CC	Sealed Stainless, Tri-Clamp, Ultralife, SiNi
YB354		3 HP	2000CC	Sealed Stainless, Tri-Clamp, Ultralife



Models

YB358		3 HP	2000CC	Sealed Stainless, Tri-Clamp Chrome
YB359		3 HP	2000CC	Sealed Stainless, Tri-Clamp, Ultralife, SiNi
YD354		3 HP	2000CC	Sealed Stainless, Tri-Clamp, Ultralife
YD358		3 HP	2000CC	Sealed Stainless, Tri-Clamp Chrome
YD359		3 HP	2000CC	Sealed Stainless, Tri-Clamp, Ultralife, SiNi
YB284		3 HP	2500CC	Sealed Stainless, Tri-Clamp, Ultralife
YB288		3 HP	2500CC	Sealed Stainless, Tri-Clamp Chrome
YB289		3 HP	2500CC	Sealed Stainless, Tri-Clamp, Ultralife, SiNi
YD284		3 HP	2500CC	Sealed Stainless, Tri-Clamp, Ultralife
YD288		3 HP	2500CC	Sealed Stainless, Tri-Clamp Chrome
YD289		3 HP	2500CC	Sealed Stainless, Tri-Clamp, Ultralife, SiNi
YB534		5 HP	2500CC	Sealed Stainless, Tri-Clamp, Ultralife
YB538		5 HP	2500CC	Sealed Stainless, Tri-Clamp Chrome
YB539		5 HP	2500CC	Sealed Stainless, Tri-Clamp, Ultralife, SiNi
YD534		5 HP	3000 CC	Sealed Stainless, Tri-Clamp, Ultralife
YD538		5 HP	3000 CC	Sealed Stainless, Tri-Clamp Chrome
YD539		5 HP	3000 CC	Sealed Stainless, Tri-Clamp, Ultralife, SiNi
YB444		5 HP	3000 CC	Sealed Stainless, Tri-Clamp, Ultralife
YB448		5 HP	3000 CC	Sealed Stainless, Tri-Clamp Chrome
YB449		5 HP	3000 CC	Sealed Stainless, Tri-Clamp, Ultralife, SiNi
YD444		5 HP	3000 CC	Sealed Stainless, Tri-Clamp, Ultralife
YD448		5 HP	3000 CC	Sealed Stainless, Tri-Clamp Chrome
YD449		5 HP	3000 CC	Sealed Stainless, Tri-Clamp, Ultralife, SiNi

YB334		5 HP	4000CC	Sealed Stainless, Tri-Clamp, Ultralife
YB338		5 HP	4000CC	Sealed Stainless, Tri-Clamp Chrome
YB339		5 HP	4000CC	Sealed Stainless, Tri-Clamp, Ultralife, SiNi
YD334		5 HP	4000CC	Sealed Stainless, Tri-Clamp, Ultralife
YD338		5 HP	4000CC	Sealed Stainless, Tri-Clamp Chrome
YD339		5 HP	4000CC	Sealed Stainless, Tri-Clamp, Ultralife, SiNi

\* YBxxx and YDxxx have different motor approvals. Consult E-Flo DCi motor manual 3A8352.

## Pump Approvals



Pump Model	Pump Approvals
YBxxxx YDxxxx	   II 2 G Ex db h IIB T3 Gb 0°C ≤ Ta ≤ 40°C

**Note:** Motor approvals are listed in the E-Flo DCi motor manual 3A8352.





# Warnings



The following warnings are for the setup, use, grounding, maintenance, and repair of this equipment. The exclamation point symbol alerts you to a general warning and the hazard symbols refer to procedure-specific risks. When these symbols appear in the body of this manual or on warning labels, refer back to these Warnings. Product-specific hazard symbols and warnings not covered in this section may appear throughout the body of this manual where applicable.









## DANGER

 	<p><b>SEVERE ELECTRIC SHOCK HAZARD</b></p> <p>This equipment is powered by more than 240V. Contact with this voltage will cause death or serious injury.</p> <ul style="list-style-type: none"> <li>Turn off and disconnect all incoming power before disconnecting any cables and before servicing equipment.</li> <li>This equipment must be grounded. Connect only to a grounded power source.</li> <li>All electrical wiring must be done by a qualified electrician and comply with all local codes and regulations.</li> </ul>
--	--

## WARNING

   	<p><b>FIRE AND EXPLOSION HAZARD</b></p> <p>Flammable fumes, such as solvent and paint fumes, in <b>work area</b> can ignite or explode. Paint or solvent flowing through the equipment can cause static sparking. To help prevent fire and explosion:</p> <ul style="list-style-type: none"> <li>Use equipment only in well-ventilated area.</li> <li>Eliminate all ignition sources; such as pilot lights, cigarettes, portable electric lamps, and plastic drop cloths (potential static sparking).</li> <li>Ground all equipment in the work area. See <b>Grounding</b> instructions.</li> <li>Keep work area free of debris, including solvent, rags, and gasoline.</li> <li>Do not plug or unplug power cords, or turn power or light switches on or off when flammable fumes are present.</li> <li>Use only grounded hoses.</li> <li>Hold gun firmly to side of grounded pail when triggering into pail. Do not use pail liners unless they are anti-static or conductive.</li> <li><b>Stop operation immediately</b> if static sparking occurs or you feel a shock. Do not use equipment until you identify and correct the problem.</li> <li>Keep a working fire extinguisher in the work area.</li> </ul>
--	--

  	<p><b>PRESSURIZED EQUIPMENT HAZARD</b></p> <p>Fluid from the equipment, leaks, or ruptured components can splash in the eyes or on skin and cause serious injury.</p> <ul style="list-style-type: none"> <li>Follow the <b>Pressure Relief Procedure</b> when you stop spraying/dispensing and before cleaning, checking, or servicing equipment.</li> <li>Tighten all fluid connections before operating the equipment.</li> <li>Check hoses, tubes, and couplings daily. Replace worn or damaged parts immediately.</li> </ul>
---	--

 <h1 style="margin: 0;">WARNING</h1>	
 	<p><b>EQUIPMENT MISUSE HAZARD</b></p> <p>Misuse can cause death or serious injury.</p> <ul style="list-style-type: none"> <li>• Do not operate the unit when fatigued or under the influence of drugs or alcohol.</li> <li>• Do not exceed the maximum working pressure or temperature rating of the lowest rated system component. See <b>Technical Specifications</b> in all equipment manuals.</li> <li>• Use fluids and solvents that are compatible with equipment wetted parts. See <b>Technical Specifications</b> in all equipment manuals. Read fluid and solvent manufacturer's warnings. For complete information about your material, request Safety Data Sheets (SDSs) from distributor or retailer.</li> <li>• Do not leave the work area while equipment is energized or under pressure.</li> <li>• Turn off all equipment and follow the <b>Pressure Relief Procedure</b> when equipment is not in use.</li> <li>• Check equipment daily. Repair or replace worn or damaged parts immediately with genuine manufacturer's replacement parts only.</li> <li>• Do not alter or modify equipment. Alterations or modifications may void agency approvals and create safety hazards.</li> <li>• Make sure all equipment is rated and approved for the environment in which you are using it.</li> <li>• Use equipment only for its intended purpose. Call your distributor for information.</li> <li>• Route hoses and cables away from traffic areas, sharp edges, moving parts, and hot surfaces.</li> <li>• Do not kink or over bend hoses or use hoses to pull equipment.</li> <li>• Keep children and animals away from work area.</li> <li>• Comply with all applicable safety regulations.</li> </ul>
 	<p><b>MOVING PARTS HAZARD</b></p> <p>Moving parts can pinch, cut, or amputate fingers and other body parts.</p> <ul style="list-style-type: none"> <li>• Keep clear of moving parts.</li> <li>• Do not operate equipment with protective guards or covers removed.</li> <li>• Pressurized equipment can start without warning. Before checking, moving, or servicing equipment, follow the <b>Pressure Relief Procedure</b> and disconnect all power sources.</li> </ul>
	<p><b>TOXIC FLUID OR FUMES HAZARD</b></p> <p>Toxic fluids or fumes can cause serious injury or death if splashed in the eyes or on skin, inhaled, or swallowed.</p> <ul style="list-style-type: none"> <li>• Read Safety Data Sheets (SDSs) to know the specific hazards of the fluids you are using.</li> <li>• Store hazardous fluid in approved containers, and dispose of it according to applicable guidelines.</li> </ul>
	<p><b>BURN HAZARD</b></p> <p>Equipment surfaces and fluid that is heated can become very hot during operation. To avoid severe burns:</p> <ul style="list-style-type: none"> <li>• Do not touch hot fluid or equipment.</li> </ul>
	<p><b>PERSONAL PROTECTIVE EQUIPMENT</b></p> <p>Wear appropriate protective equipment when in the work area to help prevent serious injury, including eye injury, hearing loss, inhalation of toxic fumes, and burns. Protective equipment includes but is not limited to:</p> <ul style="list-style-type: none"> <li>• Protective eyewear, and hearing protection.</li> <li>• Respirators, protective clothing, and gloves as recommended by the fluid and solvent manufacturer.</li> </ul>

# Typical Installation

The system accessories shown in FIG. 1 are not included. Contact your Graco distributor to design a complete system.

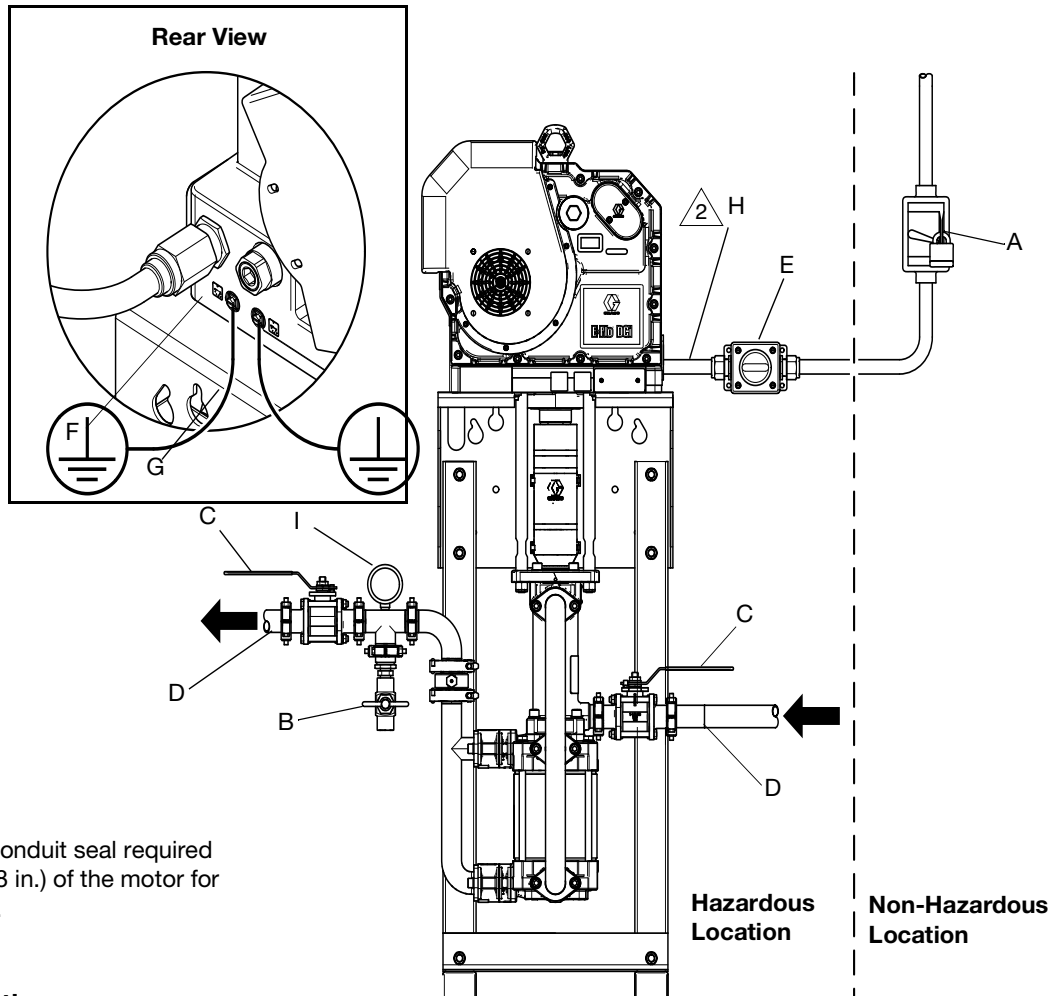

△<sub>2</sub> Explosion proof conduit seal required within 457 mm (18 in.) of the motor for U.S. and Canada.

**FIG. 1 Typical Installation**

**Key:**

- A Electrical disconnect
- B Fluid drain valve
- C Fluid shutoff valve
- D Fluid line
- E Start/stop switch
- F Ground wire connection
- G Static ground wire
- H Explosion proof conduit seal
- I Pressure gauge



## Installation

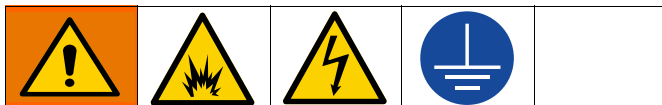

Installation of this equipment involves potentially hazardous procedures. Only trained and qualified personnel who have read and who understand the information in this manual should install this equipment. All electrical wiring must be done by a qualified electrician and comply with all local codes and regulations.

## Hazardous Location Cabling and Conduit Requirements

### Explosion Proof Requirements

All electrical wiring in the hazardous locations must be encased in approved explosion-proof conduit that is suitable for Class I, Division I, Group C and D locations. Follow all national, state, and local electrical codes and regulations.

#### US and Canada Conduit Location Requirement:

Install a conduit seal within 457 mm (18 in.) of the motor enclosure.

**Cable Rating Requirement:** Use cables with a minimum rating of 70°C (158°F). When installing DCi Link, see manual 3A8471 for cable selection.



### Flame Proof Requirements

Use appropriate conduit, connectors, and cable glands rated for Ex II 2 G. Follow all national, state, and local electrical codes and regulations.

**Cable Rating Requirement:** Use cables with a minimum rating of 70°C (158°F). When installing DCi Link, see manual 3A8471 for cable selection.

## Power Requirements

The system requires a dedicated circuit protected with a circuit breaker in each ungrounded phase.

Model by Horsepower	Voltage	Phase	Hz	kVA
3 HP (2.24 kW)	380–480 Vac	3	50/60	3.4
5 HP (3.73 kW)	380–480 Vac	3	50/60	5.7

## Location Requirements

- There must be sufficient space on all sides of the equipment for installation, operator access, maintenance, and air circulation.
- The mounting surface and mounting hardware must be strong enough to support the weight of the equipment, fluid, hoses, and stress caused during operation.
- There must be an electrical disconnect (A) within easy reach of the equipment. See FIG. 1 **Typical Installation**, page 8.

## Mount the Pump

Follow the instructions in the pump mounting kit manual to mount the pump on a stand or on the wall. See **Related Manuals**, page 2.

### Stand Mount

1. Use the **Floor Stand Mounting Pattern**, page 32.
2. Bolt the stand to the floor with M19 (5/8 in.) bolts. Use bolts that engage at least 152 mm (6 in.) into the concrete floor to prevent the pump from tipping.
3. Use shims to level the pump if needed.

## Wall Mount

1. Purchase a stand mount motor to use the wall bracket.
2. Use the wall mount bracket as a template.

**NOTE:** The bracket has two mounting hole groups. See **Mounting Bracket Pattern**, page 31

3. Drill four 7/16 in. (11 mm) holes into the wall. Bolt the bracket securely to the wall. Always use bolts and washers designed to hold in the wall's construction.
4. Attach the pump assembly to the mounting bracket.

## Required System Accessories





- **Electrical disconnect (A):** Required in the system to disconnect and isolate electricity from the motor.
- **Start stop switch (E):** Temporarily runs or stops the motor. Must be approved for hazardous locations.

## Required Fluid Line Accessories

Install accessories as shown in FIG. 1, using adapters as necessary. Make sure they meet the system's size and pressure rating requirements. See **Technical Specifications**, page 33.

- **Fluid drain valve (B):** Required in the system to relief pressure in the hose and circulation system.
- **Fluid shutoff valve (C):** shuts off fluid flow.

## Grounding

				
<p>The equipment must be grounded to reduce the risk of static sparking and electric shock. Electric or static sparking can cause fumes to ignite or explode. Improper grounding can cause electric shock. Grounding provides an escape wire for the electric current.</p>				

## Static Grounding

Use a ground wire (G) to connect the motor to a true earth ground.

1. Loosen the ground screw.
2. Insert the ground wire (G).

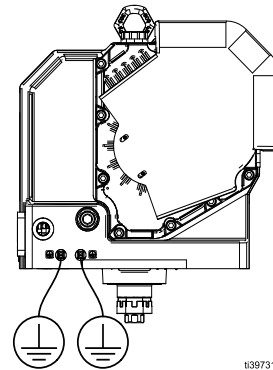
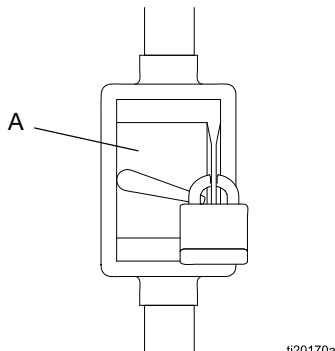

**FIG. 2 Motor ground wire location**

3. Tighten the ground screw securely.
4. Connect the other end of the ground wire (G) to a true earth ground.

## Electrical Grounding

1. Ensure that the electrical disconnect (A) is shut off and locked out.



**FIG. 3 Locked out disconnect example**

2. Remove the cover to access the motor electrical wiring compartment (EC).
3. Connect the supply ground wire to GND.

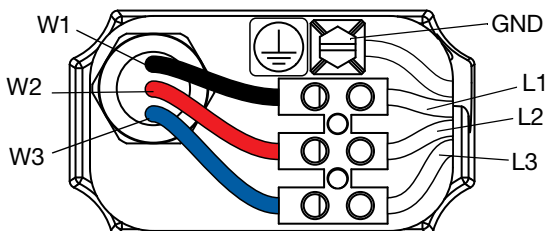

ti40756a

**FIG. 4 Motor wiring**

4. Connect the other end of the supply ground wire to a true earth ground.

## Component Grounding

**Fluid hoses:** Use only electrically conductive hoses with a maximum of 500 ft. (150 m) combined hose length to ensure grounding continuity. Check the electrical resistance of hoses. If total resistance to ground exceeds 25 megohms, replace hose immediately

**Fluid supply container:** Follow your local code.

**Solvent pails used when flushing:** Follow local code. Use only conductive metal pails, placed on a grounded surface. Do not place the pail on a non-conductive surface, such as paper or cardboard, which interrupts grounding continuity.

**To maintain grounding continuity when flushing or relieving pressure:** Hold metal part of the spray gun or valve firmly to the side of a grounded metal pail, then trigger the gun or open the valve.

## Connect Supply Wiring

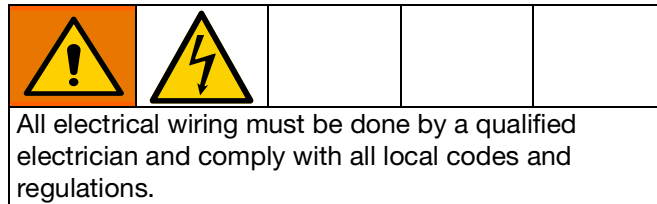

1. Ensure that the electrical disconnect (A) is shut off and locked out. See FIG. 3.
2. Bring the power wires (L1, L2, and L3) through the 3/4-14npt(f) inlet port of the electrical wiring compartment. Connect the wires to the terminal blocks.

**NOTE:** The maximum wire size that can be used with the terminal block is 8AWG (10mm<sup>2</sup>).

3. Torque terminal screws (TS) to 7 in-lb (0.79 N•m). **Do not over-torque.**
4. Close the electrical wiring compartment (EC). Torque the cover screws (CS) to 15 ft-lb (20 N•m).

1 Torque to 7 in-lb (0.79 N•m)

2 Torque to 15 ft-lb (20 N•m)

3 A conduit seal is required within 457 mm (18 in.) of the motor for US and Canadian installations.

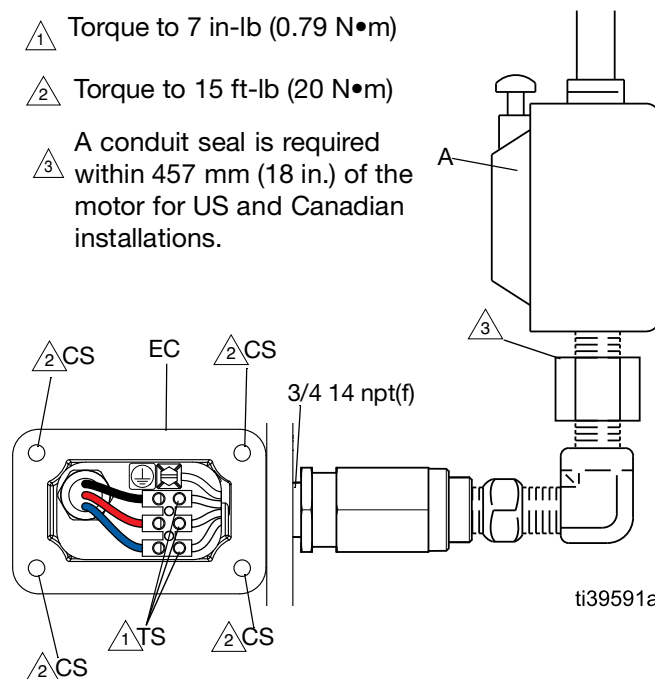

**FIG. 5 Motor electrical compartment wires**

## Install the Fill Cap

The motor is pre-filled with oil. Replace the shipping plug with the fill cap (FC) before first use. Install fill cap and hand tight.

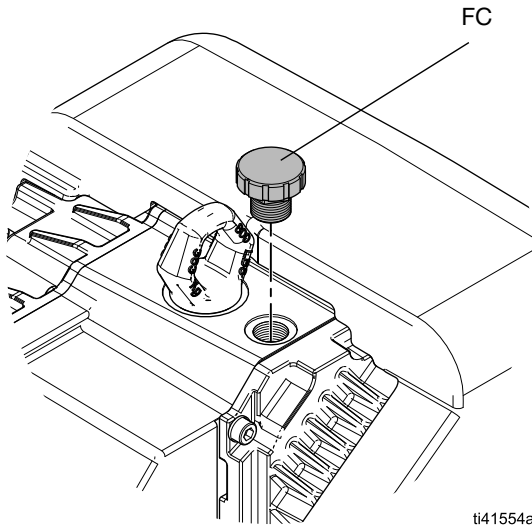

**Fig. 6 Fill cap**

ti41554a

## Flush Before Using the Equipment

The pump fluid section was tested with lightweight oil, which is left in the fluid passages to protect parts. To avoid contaminating your fluid with oil, flush the equipment with a compatible solvent before using the equipment.

# Operation

## Pressure Relief Procedure



Follow the Pressure Relief Procedure whenever you see this symbol.



This equipment stays pressurized until pressure is manually relieved. To help prevent serious injury from pressurized fluid, such as splashing fluid and moving parts, follow the **Pressure Relief Procedure** when you stop dispensing and before cleaning, checking, or servicing the equipment.

1. Shut off the start/stop switch (E).
2. Shut off and lock out the electrical disconnect (A).
3. Open the fluid drain valve (B), having a grounded waste container ready to catch drainage. Leave

open until you are ready to pressurize the system again.

## Startup

1. Follow the motor start up instructions in your motor manual. See **Related Manuals**, page 2
2. Run the pump at a slow speed until the pump primes the fluid lines and forces air out of the system.

## Shutdown

1. Follow the **Pressure Relief Procedure**, page 13.
2. Follow the shutdown instructions in the motor manual. See **Related Manuals**, page 2

# Maintenance

## Preventive Maintenance Schedule

The operating conditions of your particular system determine how often maintenance is required.

Establish a preventive maintenance schedule by recording when and what kind of maintenance is needed, and then determine a regular schedule for checking your system.

## Flushing Procedure



To avoid fire and explosion, always ground equipment and waste container. To avoid static sparking and injury from splashing, always flush at the lowest possible pressure.

- Flush before changing fluids, before fluid can dry in the equipment, before storing, and before repairing equipment.
  - Flush at the lowest pressure possible. Check connections for leaks and tighten as necessary.
  - Flush with a fluid that is compatible with the fluid being dispensed and the equipment wetted parts
1. Follow the **Pressure Relief Procedure** on page 13.
  2. Supply a compatible flushing material to the system.
  3. Set pump to lowest possible fluid pressure, and start the pump.
  4. Flush long enough to thoroughly clean the system.
  5. Follow the **Pressure Relief Procedure** on page 13.

## Change the Oil

Change the oil after a break-in period of 200,000–300,000 cycles. After the break-in period, change the oil once a year.

1. Place a minimum 2 quart (1.9 liter) container under the oil drain port.
2. Remove the oil drain plug.
3. Allow all oil to drain from the motor.
4. Reinstall the oil drain plug. Torque to 15–20 ft-lb (20–27 N•m).
5. Add oil. See page 15.

## Check Oil Level

Check the oil level in the sight glass (SG). The oil level should be near the halfway point of the sight glass when the unit is not running.

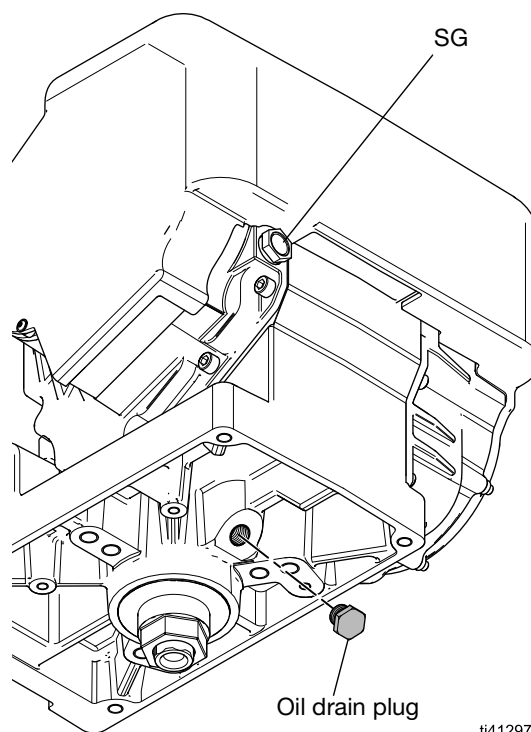

**FIG. 7 Oil drain plug and sight glass**

ti41297a

## Add Oil

1. Open the fill cap (FC).
2. Add a compatible oil. See **Technical Specifications** on page 33.

**NOTE:** The oil capacity is 2.0 quarts (1.9 liters). Do not overfill.

3. Reinstall the fill cap (FC) and hand tight.

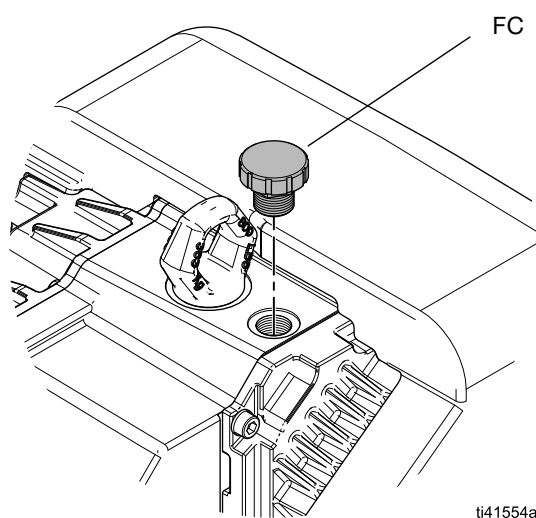

ti41554a

**FIG. 8 Fill cap location**

---

# Troubleshooting

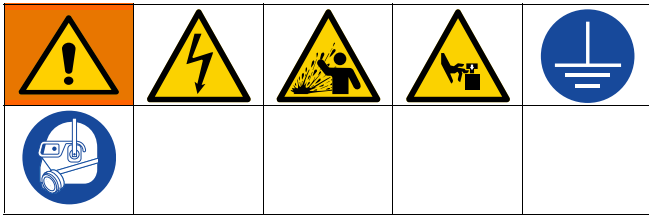

1. Follow the **Pressure Relief Procedure** on page 13, before checking or repairing the equipment.
2. Check all possible remedies before disassembling the pump.

**NOTE:** The LED on the motor will blink if an error is detected. Refer to the motor manual for Error Code Troubleshooting.

Problem	Cause	Solution
Pump output low on both strokes.	Inadequate supply voltage	Verify supply voltage. See <b>Technical Specifications</b> , page 33.
	Exhausted or inadequate fluid supply	Refill the pump fluid supply.
	Clogged fluid components	Clear clogged components. Follow the <b>Pressure Relief Procedure</b> , page 13 followed by the <b>Flushing Procedure</b> , page 14.
	Worn piston seal	Replace piston seal. ✓
Pump output low on only one stroke.	Held open or worn ball check valves	Check and repair ball check valves. ✓
	Worn piston packing	Replace packings. ✓
No output.	Improperly installed ball check valves	Check and repair the ball check valves. ✓
Pump operates erratically.	Exhausted or inadequate fluid supply	Refill the pump fluid supply.
	Held open or worn ball check valves	Check and repair the ball check valves. ✓
	Worn piston seal	Replace piston seal. ✓
Pump will not operate.	Inadequate supply voltage	Verify supply voltage. See <b>Technical Specifications</b> , page 33.
	Clogged fluid components	Clear clogged components. Follow the <b>Pressure Relief Procedure</b> , page 13 followed by the <b>Flushing Procedure</b> , page 14.
	Fluid dried on piston rod	Disassemble and clean pump. ✓ <b>NOTE:</b> Stop pump at bottom of stroke to avoid piston rod damage.

✓ See your lower repair manual that corresponds with your model. Repair manuals vary by model. Find your specific lower model in the **Pump Matrix** on page 19.



# Repair

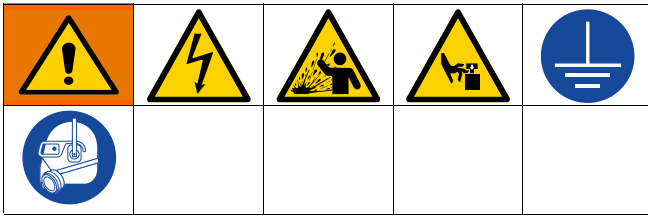

## Prepare Equipment for Service

1. Stop the pump at the bottom of its stroke.
2. Shut off and lock out the electrical disconnect (A).
3. Follow the **Pressure Relief Procedure**, page 13.
4. Follow the **Flushing Procedure**, page 14.
5. Disconnect the hoses from the lower and plug the ends to prevent fluid contamination.

## Disconnect the Pump Lower

1. Disconnect the lower from the motor. Use a repair manual that corresponds with your model. Find your specific lower model in the **Pump Matrix** on page 19.
2. Remove the 2-piece coupler shield (10) by inserting a screwdriver straight into the slot, and using it as a lever to release the tab. Repeat for all tabs. Do not use the screwdriver to pry the shields apart.

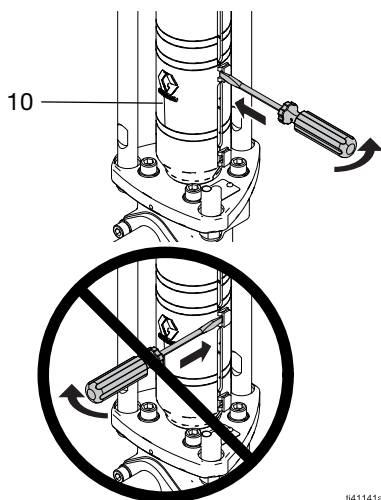

041141a

**FIG. 9 Coupler shield assembly**

3. Loosen the coupling nut (9) and remove the collars (8). Remove the coupling nut (9) from the piston rod. Unscrew the locknuts (6) from the tie rods (4). Separate the lower (5) from the tie rods (4).

## Reconnect the Lower and Motor

1. If the coupling adapter (7) and tie rods (4) have not been disassembled from the motor (3), skip to Step 2.

If the coupling adapter (7) and tie rods (4) have been disassembled from the motor (3), follow these steps:

- a. Screw the tie rods (4) into the motor (3) and torque to 50-60 ft-lb (68-81 N•m).
  - b. Apply red thread locker to the coupling adapter (7).
  - c. Screw the coupling adapter (7) into the motor shaft and torque to 90-100 ft-lb (122-135 N•m).
  - d. Continue to step 2.
2. Assemble the coupling nut (9) over the piston rod.
  3. Orient the lower (5) to the motor (3). Position the lower on the tie rods (4).
  4. If you are reusing lock nuts (6) and the nylon of the lock nut is worn or cut, add blue thread locker to the tie rod threads.

5. Screw the lock nuts (6) onto the tie rods (4). Leave the lock nuts (6) loose enough to allow the lower to move so that it can be aligned correctly.

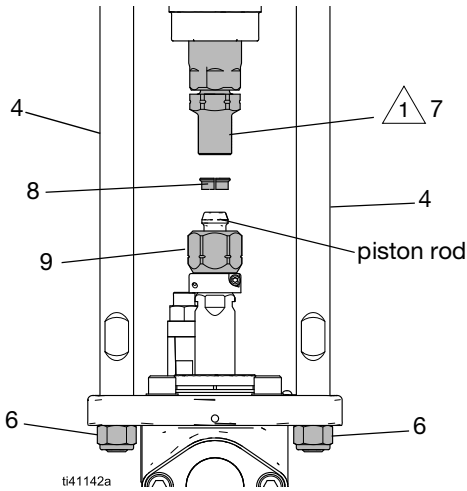

 Apply red thread locker

**FIG. 10 Coupling nut and piston rod**

6. Insert the collars (8) into the coupling nut (9). Tighten the coupling nut (9) onto the coupling adapter (7) and torque to 90–100 ft-lb (122–135 N•m) to align the motor shaft with the piston rod.
7. Tighten the lock nuts (6) and torque to 50-60 ft-lb (68-81 N•m).
8. Install the shields (10) by engaging the bottom lips with the groove in the top plate. Snap the two shields together.

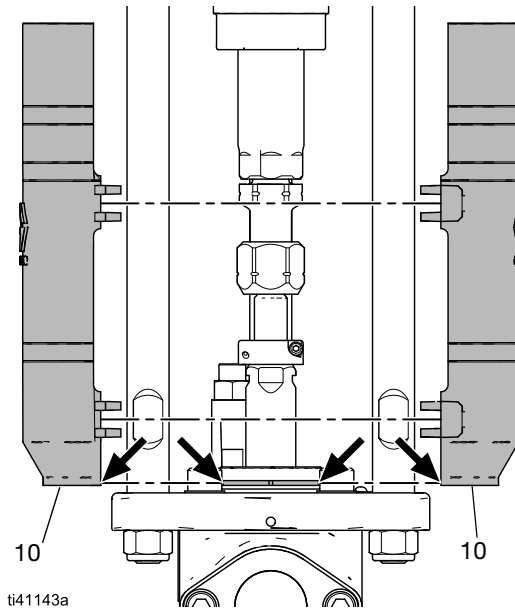

**FIG. 11 Shield assembly**

9. Test the pump operation before reinstalling it in the system.
  - a. Connect hoses and flush the pump. See **Flushing Procedure**, page 14.
  - b. Check for smooth operation and leaks while flushing.
  - c. Adjust or repair as necessary before reinstalling in the system.
10. Reconnect the pump ground wire before operating.

# Pump Matrix

## Yx90xx

Pumps with 3 HP motor and 750cc lower displacement

Pump Model	Motor	Lower
YB9040	YM1132	26B217
YB9041	YM1132	26B217
YB9080	YM1132	26B218
YB9081	YM1132	26B218
YD9040	YM1134	26B217
YD9041	YM1134	26B217
YD9080	YM1134	26B218
YD9081	YM1134	26B218

## Yx45xx

Pumps with 3 HP motor and 1500cc lower displacement

Pump Model	Motor	Lower
YB4540	YM1132	17K658
YB4541	YM1132	17K658
YB4580	YM1132	25N408
YB4581	YM1132	25N408
YB4590	YM1132	25R340
YB4591	YM1132	25R340
YD4540	YM1134	17K658
YD4541	YM1134	17K658
YD4580	YM1134	25N408
YD4581	YM1134	25N408
YD4590	YM1134	25R340
YD4591	YM1134	25R340

## Yx35xx

Pumps with 3 HP motor and 2000cc lower displacement

Pump Model	Motor	Lower
YB3540	YM1132	17K659
YB3541	YM1132	17K659
YB3580	YM1132	25N410
YB3581	YM1132	25N410
YB3590	YM1132	25R341
YB3591	YM1132	25R341
YD3540	YM1134	17K659
YD3541	YM1134	17K659
YD3580	YM1134	25N410
YD3581	YM1134	25N410
YD3590	YM1134	25R341
YD3591	YM1134	25R341

## Yx62xx

Pumps with 3 HP motors and 1000cc lower displacement

Pump Model	Motor	Lower
YB6240	YM1132	17K657
YB6241	YM1132	17K657
YB6280	YM1132	25N404
YB6281	YM1132	25N404
YD6240	YM1134	17K657
YD6241	YM1134	17K657
YD6280	YM1134	25N404
YD6281	YM1134	25N404

## Yx28xx

Pumps with 3 HP motor and 2500cc lower displacement

Pump Model	Motor	Lower
YB2840	YM1132	17Z387
YB2841	YM1132	17Z387
YB2880	YM1132	17Z390
YB2881	YM1132	17Z390
YB2890	YM1132	18F379
YB2891	YM1132	18F379
YD2840	YM1134	17Z387
YD2841	YM1134	17Z387
YD2880	YM1134	17Z390
YD2881	YM1134	17Z390
YD2890	YM1134	18F379
YD2891	YM1134	18F379

## Yx53xx

Pumps with 5 HP motor and 2500cc lower displacement

Pump Model	Motor	Lower
YB5340	YM1152	17Z387
YB5341	YM1152	17Z387
YB5380	YM1152	17Z390
YB5381	YM1152	17Z390
YB5390	YM1152	18F379
YB5391	YM1152	18F379
YD5340	YM1154	17Z387
YD5341	YM1154	17Z387
YD5380	YM1154	17Z390
YD5381	YM1154	17Z390
YD5390	YM1154	17Z387
YD5391	YM1154	17Z387

## Yx44xx

Pumps with 5HP motor and 3000cc lower displacement

Pump Model	Motor	Lower
YB4440	YM1152	17Z388
YB4441	YM1152	17Z388
YB4480	YM1152	17Z391
YB4481	YM1152	17Z391
YB4490	YM1152	18F380
YB4491	YM1152	18F380
YD4440	YM1154	17Z388
YD4441	YM1154	17Z388
YD4480	YM1154	17Z391
YD4481	YM1154	17Z391
YD4490	YM1154	18F380
YD4491	YM1154	18F380

## Yx33xx

Pumps with 5HP motor and 4000cc lower displacement

Pump Model	Motor	Lower
YB3340	YM1152	17Z389
YB3341	YM1152	17Z389
YB3380	YM1152	17Z392
YB3381	YM1152	17Z392
YB3390	YM1152	18F381
YB3391	YM1152	18F381
YD3340	YM1154	17Z389
YD3341	YM1154	17Z389
YD3380	YM1154	17Z392
YD3381	YM1154	17Z392
YD3390	YM1154	18F381
YD3391	YM1154	18F381

# Parts

## Yx28xx, Yx33xx, Yx44xx, and Yx53xx

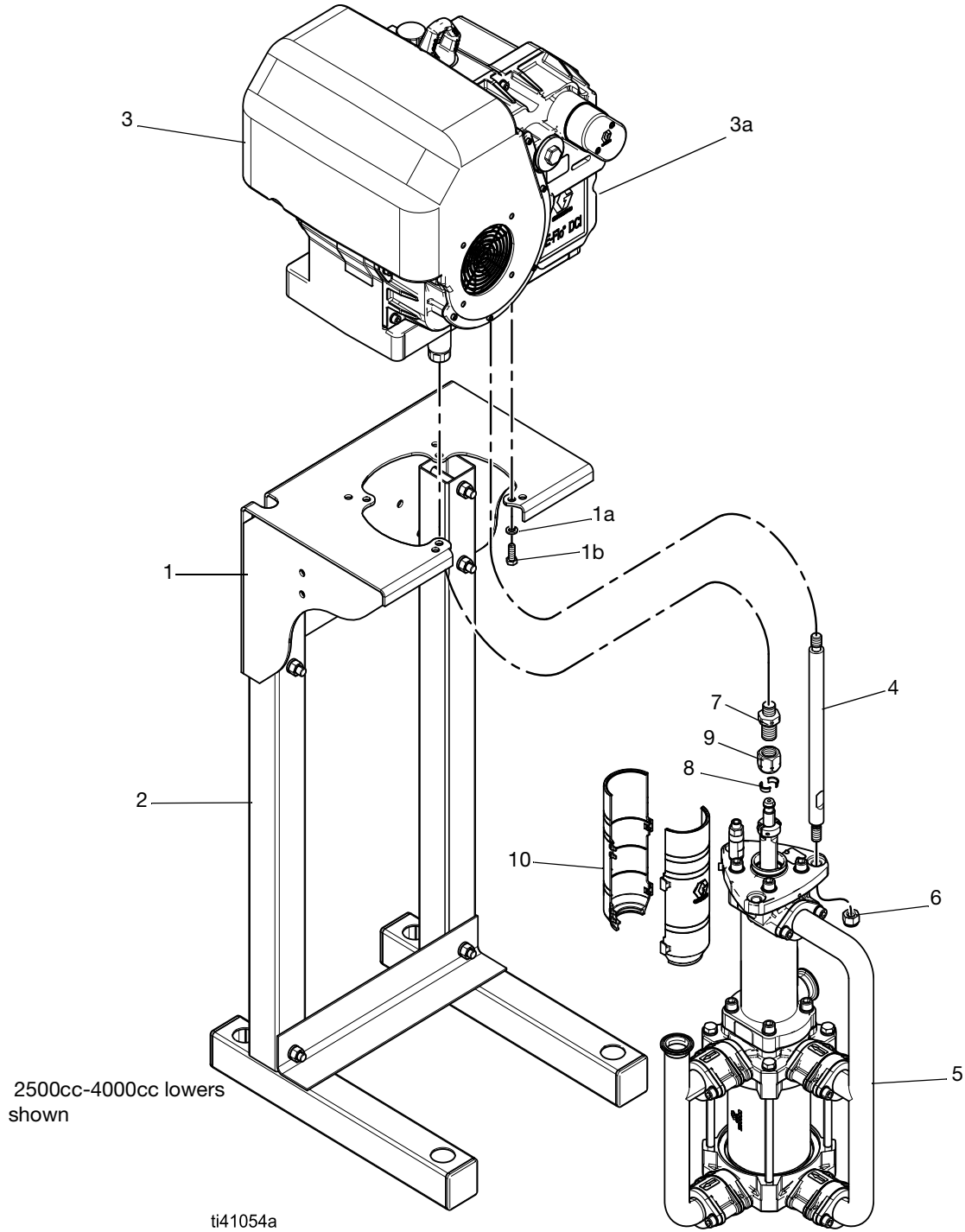

# Yx35xx, Yx62xx, Yx90xx, and Yx45xx

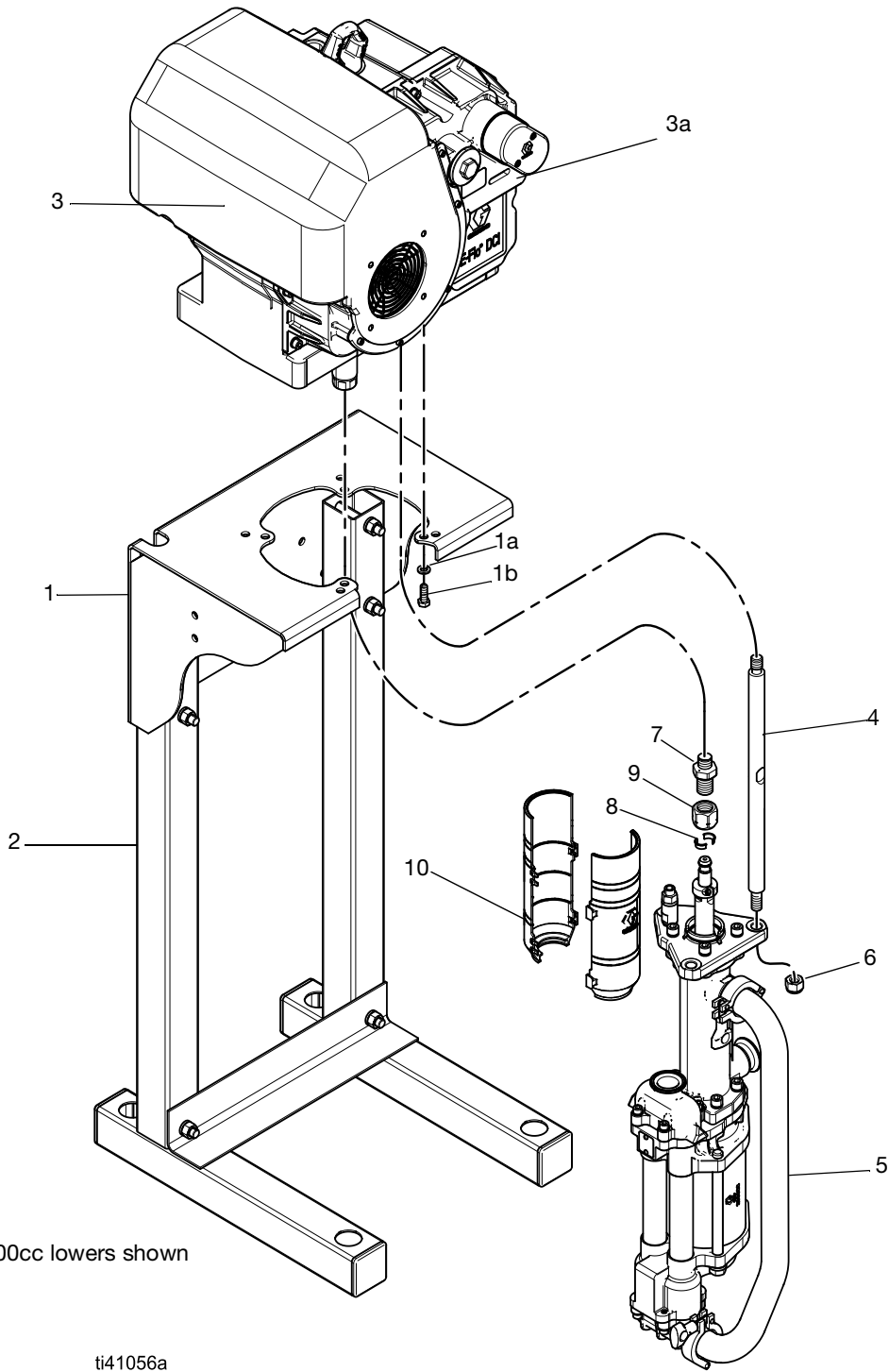

## Yx28xx, Yx33xx, Yx44xx, Yx53xx, Yx45xx, Yx62xx, Yx90xx, and Yx35xx

Ref.	Part No.	Description	Qty.
1	255143	Mounting Hardware Bracket Kit (includes items 1a and 1b); models Yxxxx2 only	1
1a	-	Washer	4
1b	-	Bolt	4
2	253692	Floor Stand Kit (includes ref. 1-9); models Yxxxx1 only	1
3	-	Motor (includes 3a); See <b>Pump Matrix</b> starting on page 19 for motor part number	1
3a ▲	20A695	Safety Label (YBxxx models)	1
	19Y501	Safety Label (YDxxx models)	
4	16X771	Tie Rod	3
5	-	Lower. See <b>Pump Matrix</b> starting on page 19 for lower part number	1
6	108683	Lock Nut	3
7	15H369	Coupling Adapter	1
8	184128	Coupling Collar	2
9	17F000	Coupling Nut	1
10	24F251	Coupler Shield Kit (includes 2 pieces)	1

▲ Replacement safety labels, tags and cards are available at no cost.

# Dimensions

## Yx45xx, Yx62xx, Yx90xx, and Yx35xx

A	59.2 in.	1,50.4 cm
B	17.0 in.	43.2 cm
C	55.7 in.	141.5 cm
D	20.4 in.	51.8 cm
E	21.0 in.	53.3 cm
F	19.6 in.	49.8 cm
G	11.1 in.	28.2 cm

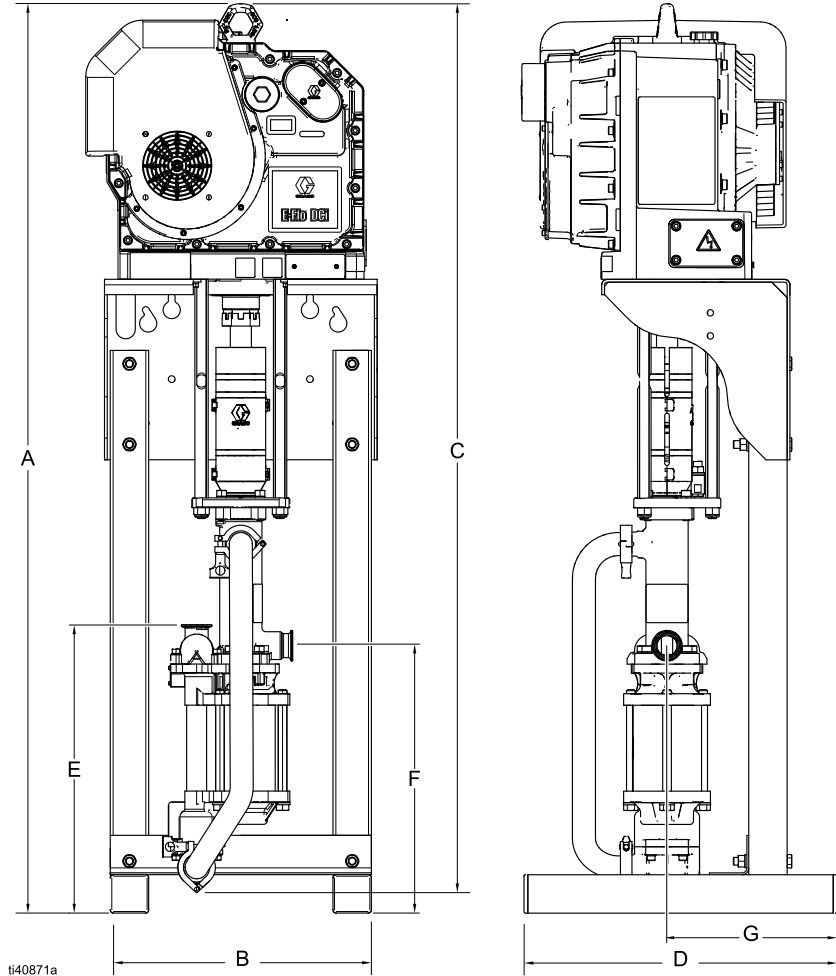



### Yx28xx, Yx33xx, Yx44xx, and Yx53xx

A	59.2 in.	1,50.4 cm
B	17.0 in.	43.2 cm
C	52.1 in.	312.3 cm
D	20.4 in.	51.8 cm
E	19.9 in.	50.5 cm
F	19.6 in.	49.8 cm
G	11.1 in.	28.2 cm

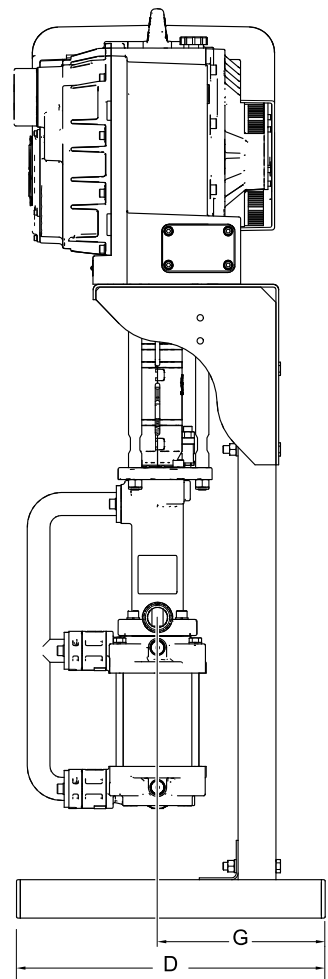
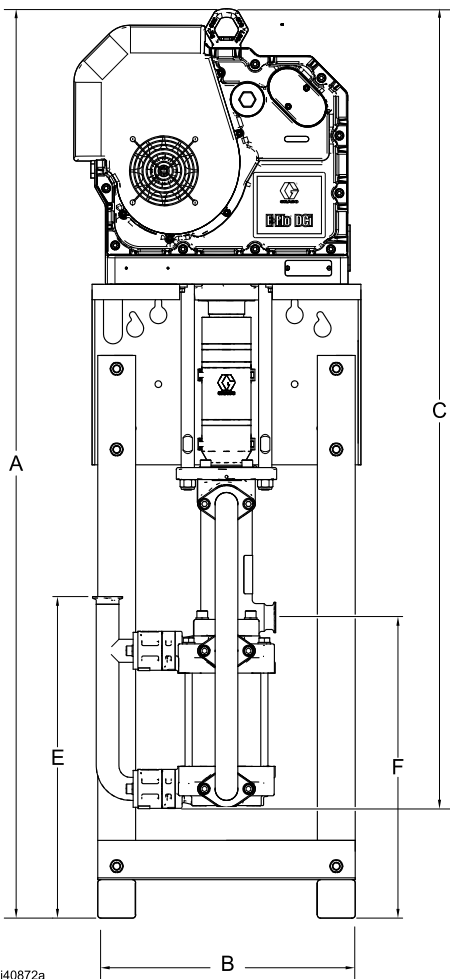

# Performance Charts

To find the fluid pressure (psi/bar/MPa) at a specific fluid flow (gpm/lpm) and percentage of maximum force:

1. Locate the desired fluid flow in the scale at the bottom of the chart.
2. Follow the vertical line up to the intersection with the selected percentage of maximum force.
3. Follow left to the vertical scale to read the fluid outlet pressure.

**Performance Chart Key:**

	Maximum Force Percentage
A	40%
B	70%
C	100%

**NOTE:** The charts show the motor operating at 40%, 70%, and 100% of maximum force. These values are approximately equivalent to an air motor operating at 40, 70, and 100 psi. Dashed lines are the power usage at the operating point and motor force. Pumps tested with 10 weight hydraulic oil.

**Yx90xx: Pumps with 3 HP motor and 750cc lower displacement**

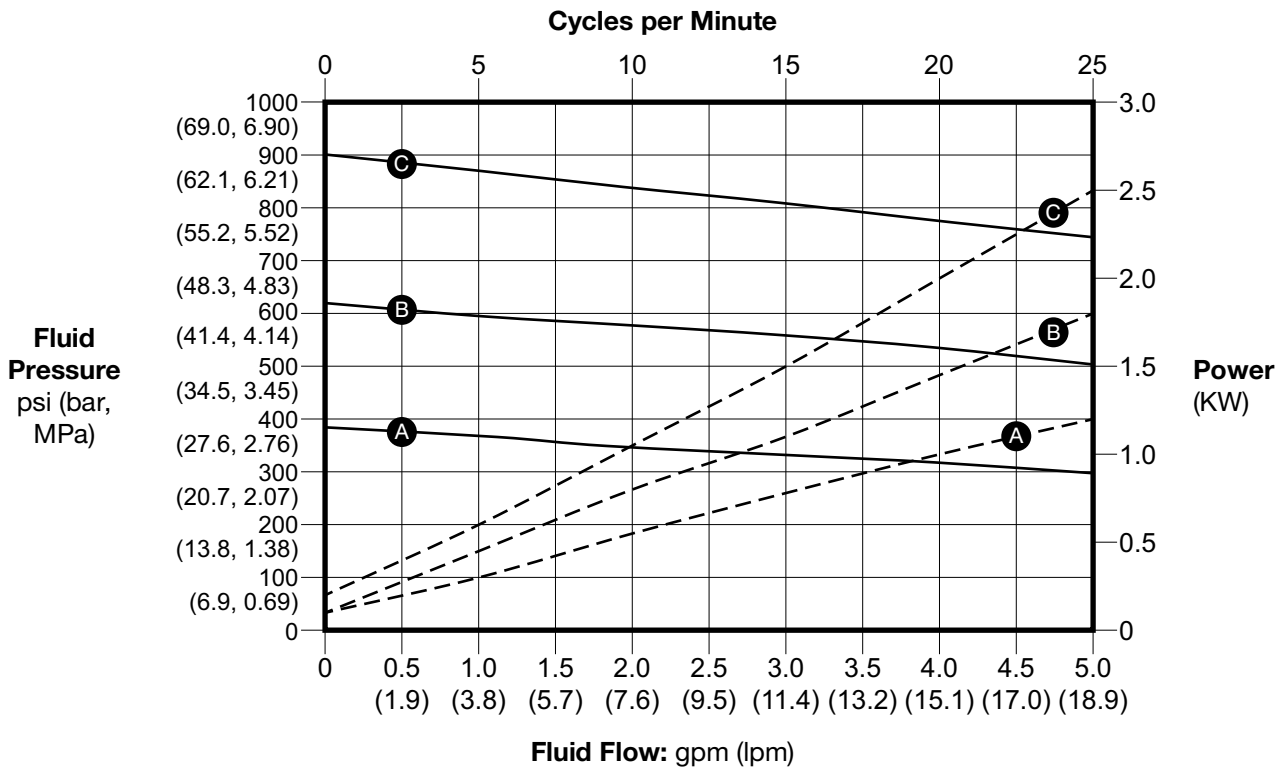

**Yx45xx: Pumps with 3 HP motor and 1500cc lower displacement**

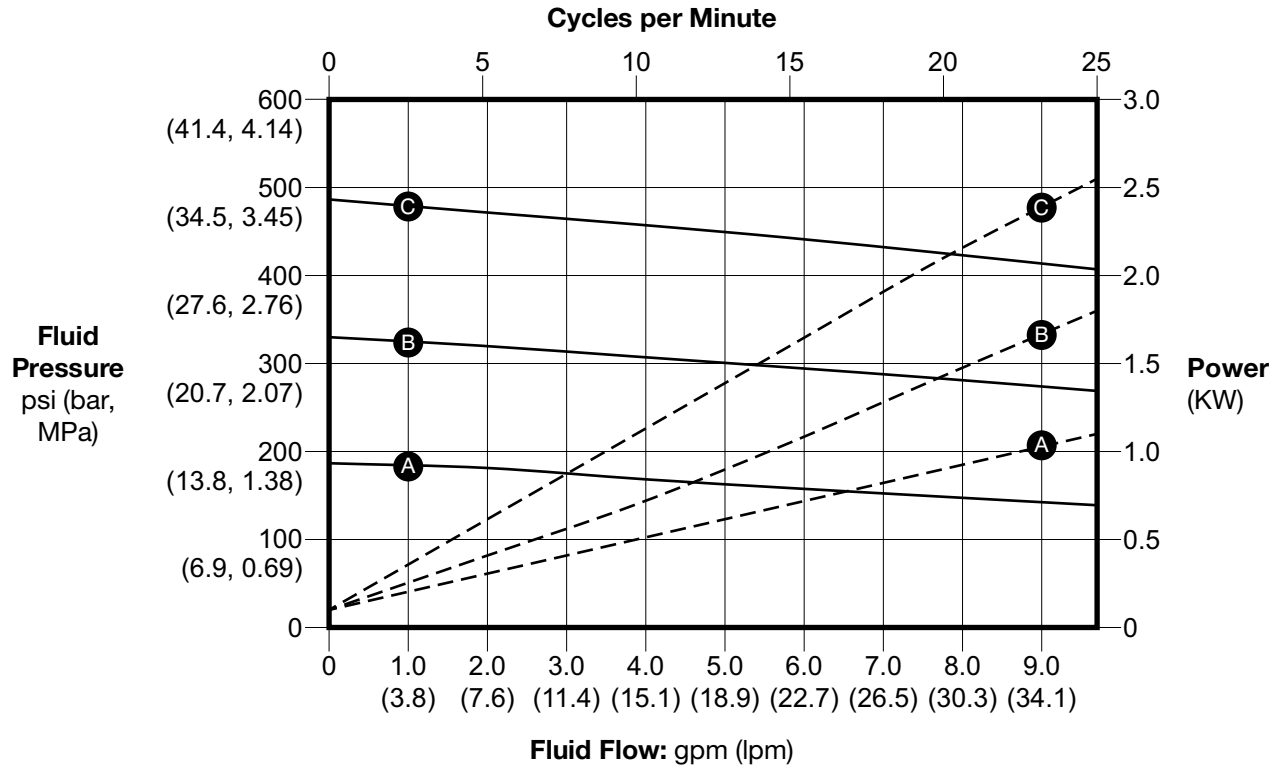

**Yx35xx: Pumps with 3 HP motor and 2000cc lower displacement**

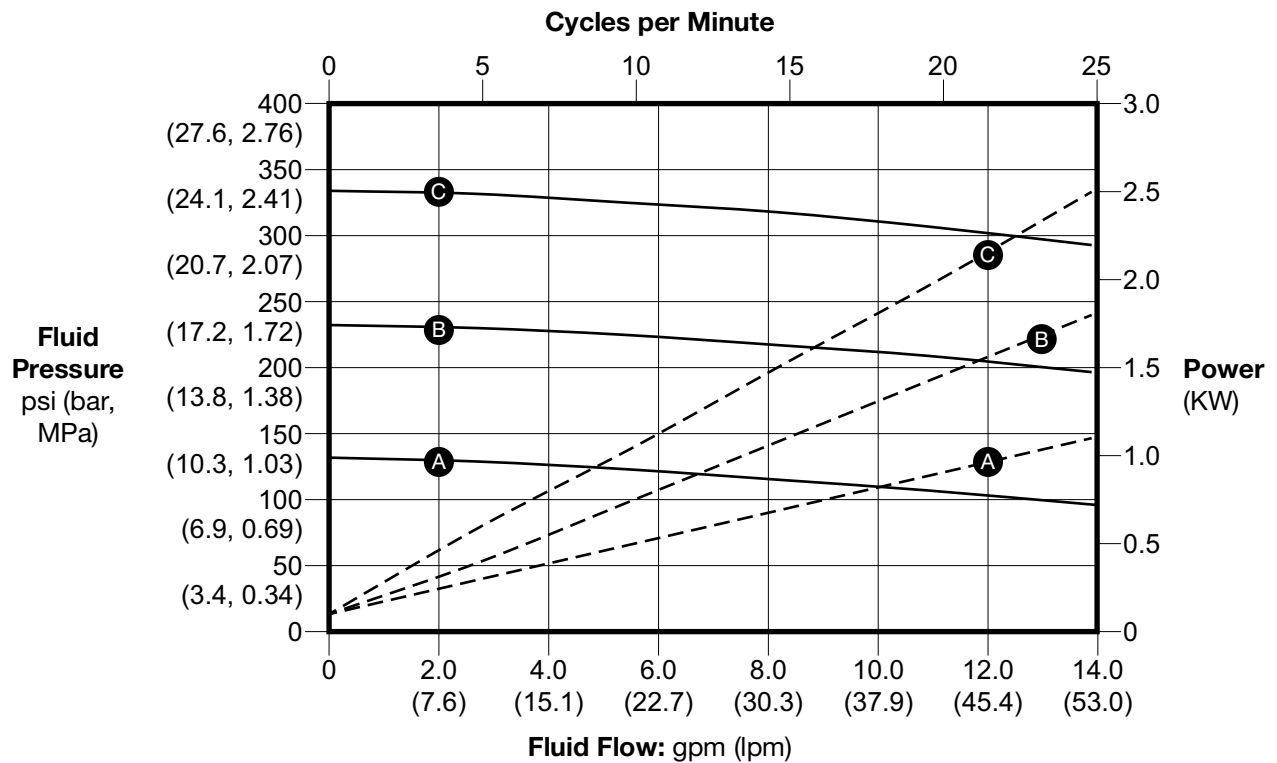

**Yx28xx: Pumps with 3 HP motor and 2500cc lower displacement**

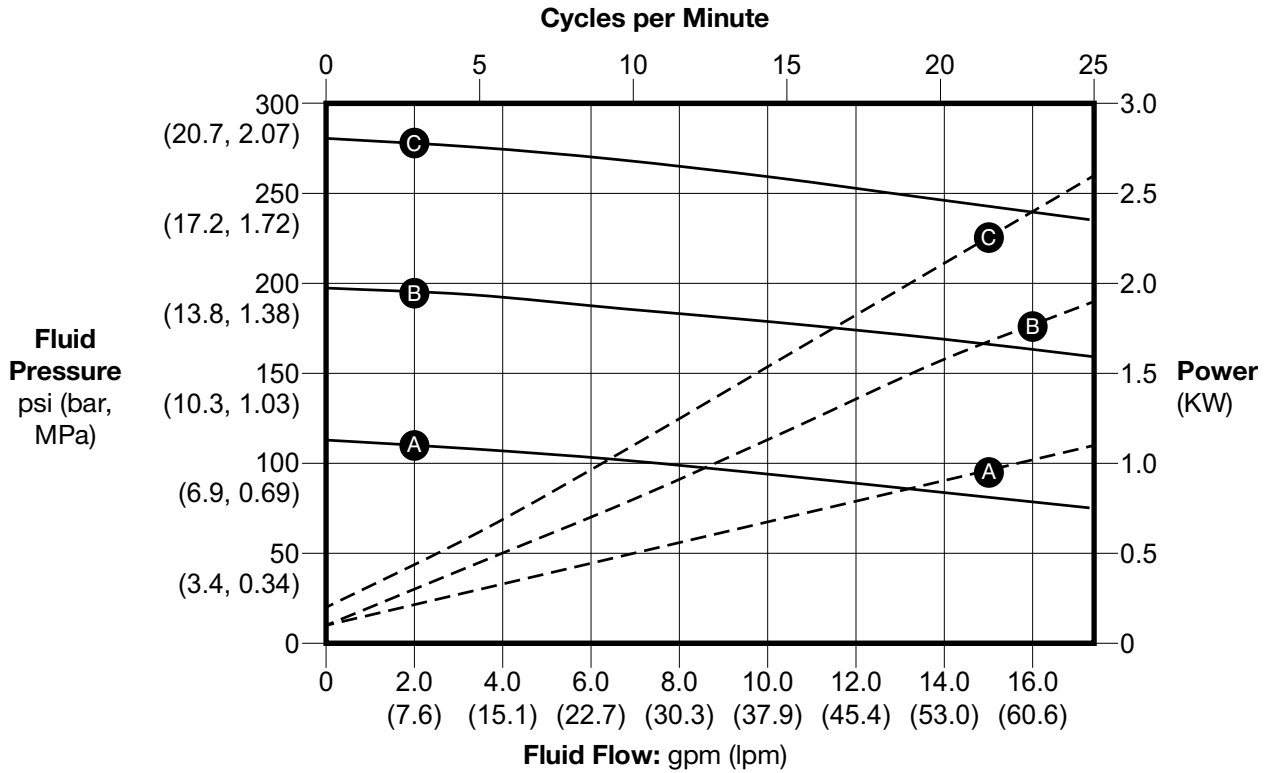

**Yx62xx: Pumps with 3 HP motor and 1000cc lower displacement**

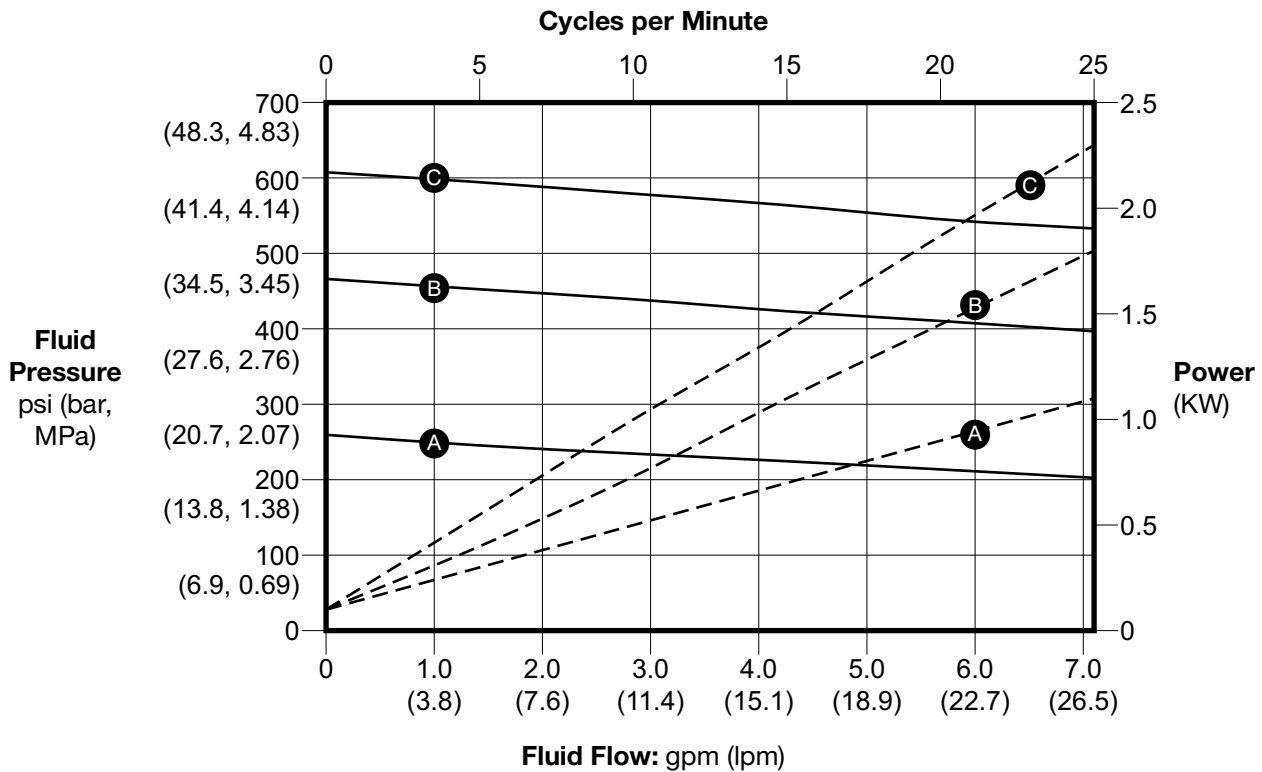

**Yx53xx: Pumps with 5 HP motor and 2500cc lower displacement**

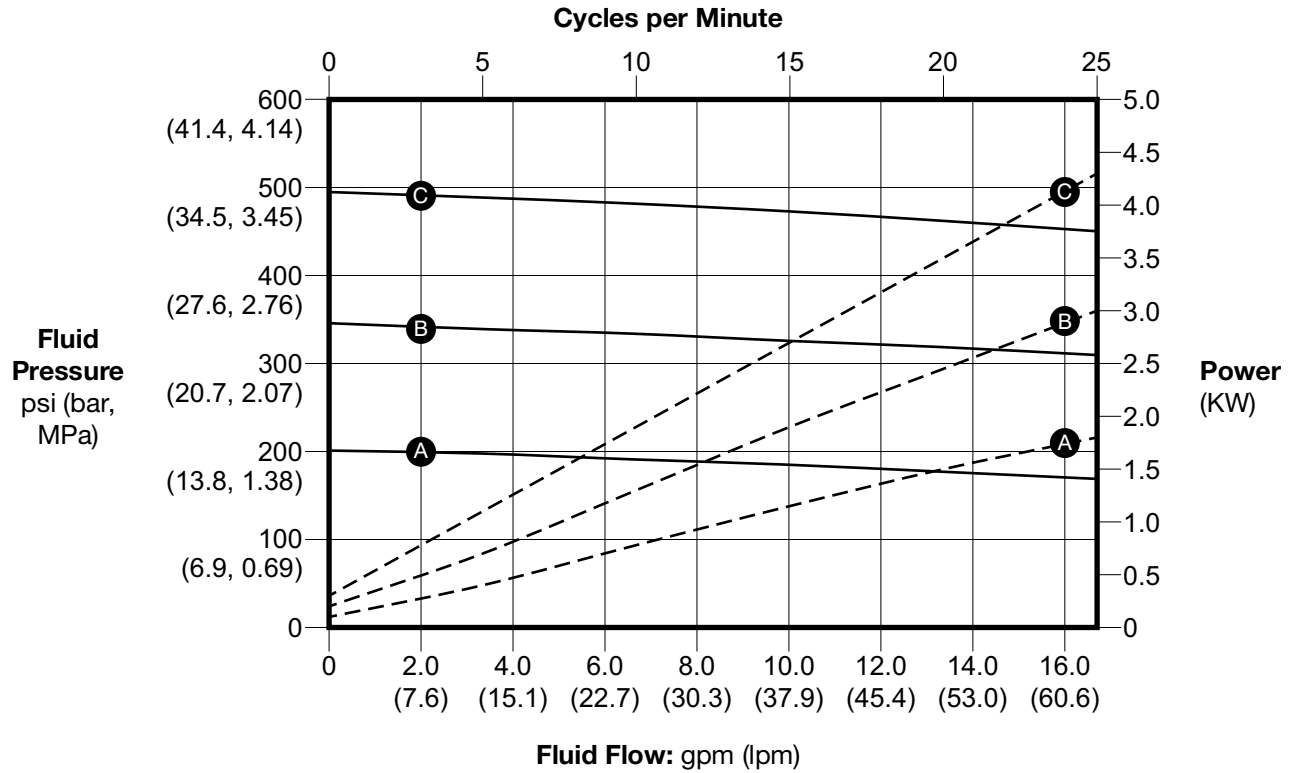

**Yx44xx: Pumps with 5HP motor and 3000cc lower displacement**

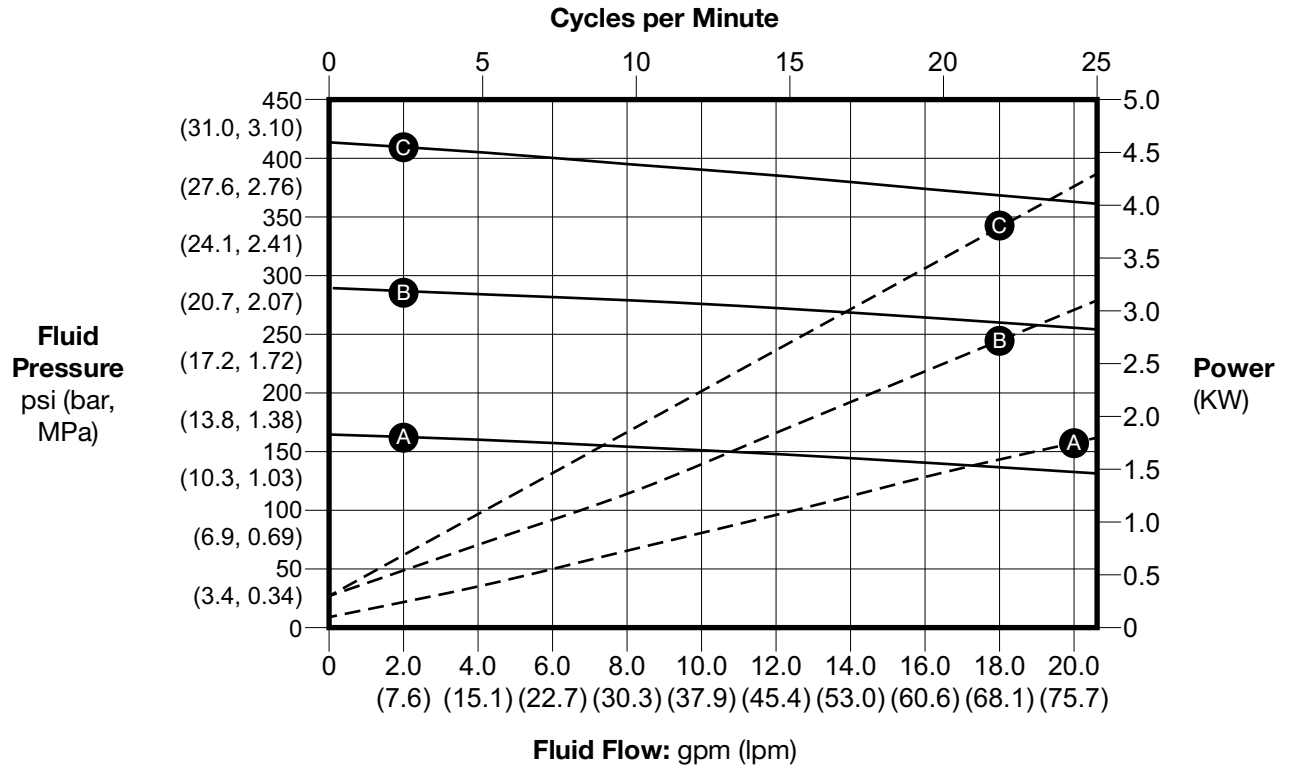

**Yx33xx: Pumps with 5HP motor and 4000cc lower displacement**

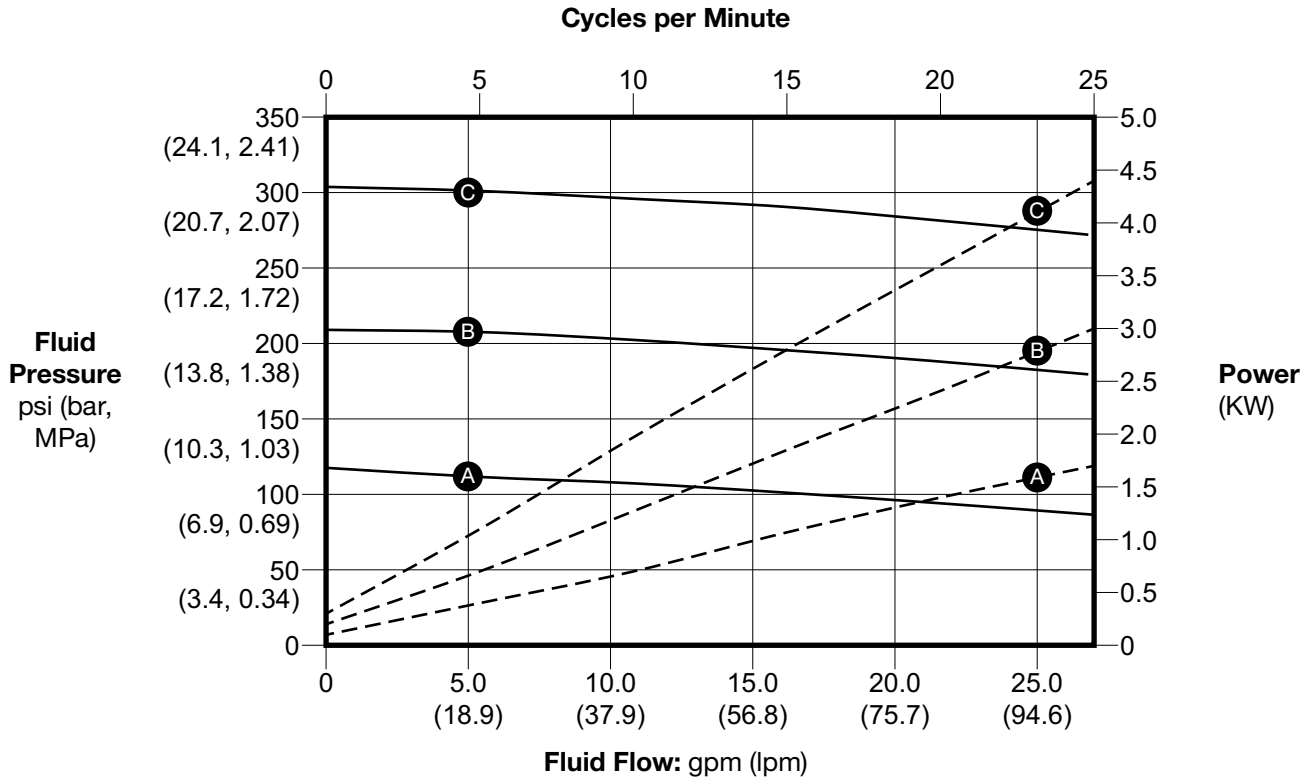

# Mounting Hole Patterns

## Mounting Bracket Pattern

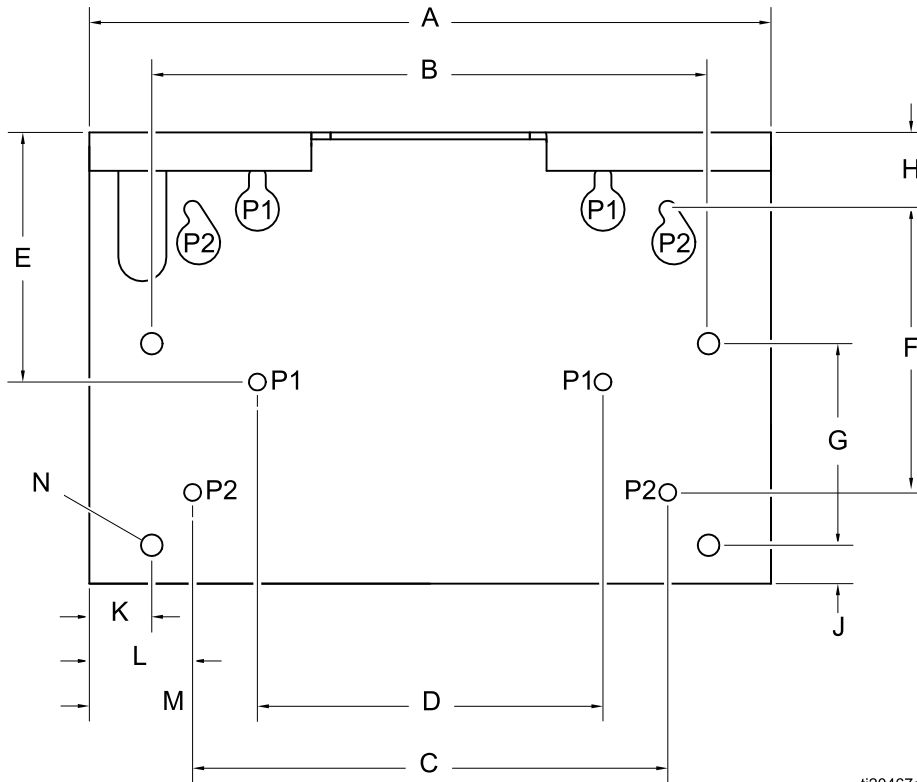

t20467a

<b>A</b>	17.8 in. (451 mm)
<b>B</b>	14.5 in. (368 mm)
<b>C</b>	12.4 in. (314 mm)
<b>D</b>	9.0 in. (229 mm)
<b>E</b>	5.4 in. (137 mm)
<b>F</b>	7.4 in. (187 mm)
<b>G</b>	5.3 in. (133 mm)
<b>H</b>	2.0 in. (51 mm)
<b>J</b>	1.0 in. (25 mm)
<b>K</b>	1.6 in. (41 mm)
<b>L</b>	2.7 in. (69 mm)
<b>M</b>	4.4 in. (112 mm)
<b>N</b>	Four 0.562 in. (14 mm) diameter holes for mounting to stand
<b>P</b>	Four 0.438 in. (11 mm) diameter holes for mounting to wall

# Floor Stand Mounting Pattern

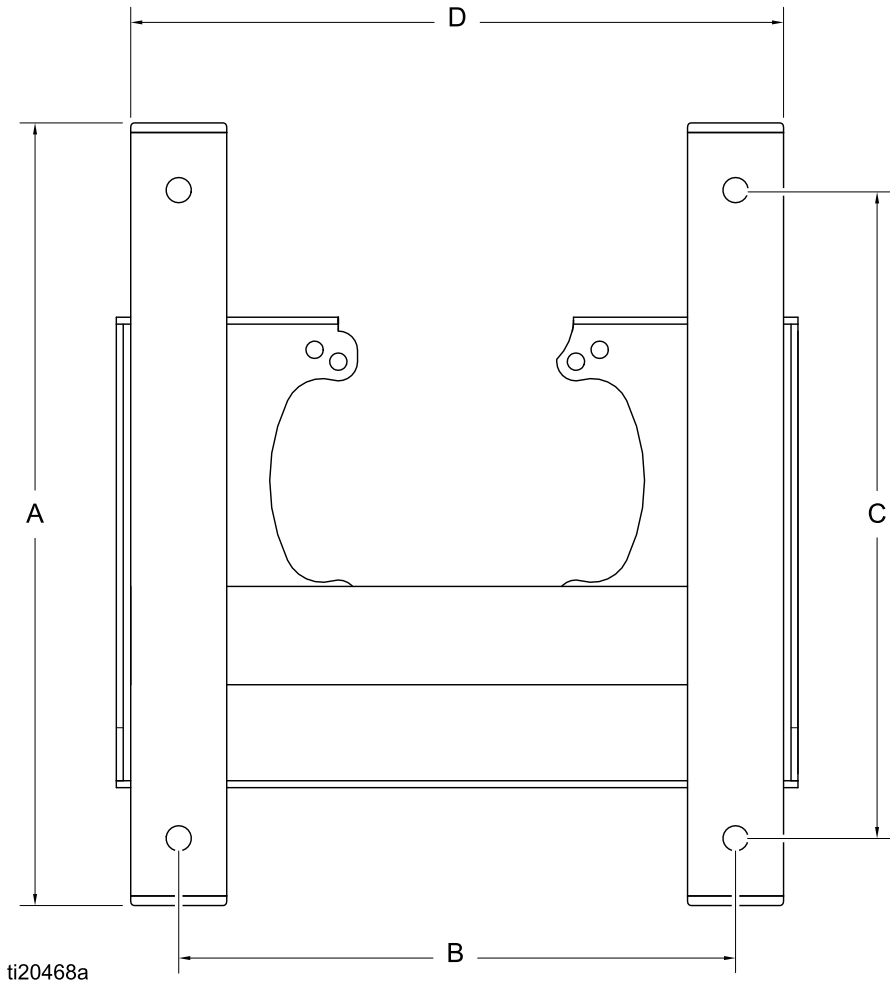

<b>A</b>	19.88 in. (505.0 mm)
<b>B</b>	14.50 in. (368.3 mm)
<b>C</b>	16.88 in. (428.8 mm)
<b>D</b>	17.0 in. (431.8 mm)



# Technical Specifications

## E-Flo DCi 4-Ball Pumps

Models	Motor Rating	Lower Displacement	Flow Rate at 20 cpm	Maximum Fluid Working Pressure	Pump Weight	Fluid Inlet Connection	Fluid Outlet Connection
Yx90xx	3 HP (2.24 kW) (3.4 kVA) 380–480 Vac 3 phase 50/60 Hz	750cc	4.0 gpm (15 lpm)	900 psi (62 bar, 6.2 mPa)	228 lb (103 kg)	1.5 in. tri-clamp	1.5 in. npt
Yx62xx	3 HP (2.24 kW) 3.4 kVA 380–480 Vac 3 phase 50/60 Hz	1000cc	5.3 gpm (20 lpm)	600 psi (41.4 bar, 4.1 mPa)	229 lb (104 kg)	1.5 in. tri-clamp	1.5 in. tri-clamp
Yx45xx	3 HP (2.24 kW) 3.4 kVA 380–480 Vac 3 phase 50/60 Hz	1500cc	7.9 gpm (30 lpm)	450 psi (31 bar, 3.1 mPa)	230 lb (104 kg)	1.5 in. tri-clamp	1.5 in. tri-clamp
Yx35xx	3 HP (2.24 kW) 3.4 kVA 380–480 Vac 3 phase 50/60 Hz	2000cc	10.6 gpm (40 lpm)	330 psi (22.8 bar, 2.3 mPa)	233 lb (106 kg)	1.5 in. tri-clamp	1.5 in. tri-clamp
Yx28xx	3 HP (2.24 kW) 3.4 kVA 380–480 Vac 3 phase 50/60 Hz	2500cc	13.2 gpm (50 lpm)	280 psi (19 bar, 1.9 mPa)	247 lb (112 kg)	1.5 in. tri-clamp	1.5 in. tri-clamp
Yx53xx	5 HP (3.73 kW) 5.7 kVA 380–480 Vac 3 phase 50/60 Hz	2500cc	13.2 gpm (50 lpm)	460 psi (31.7 bar, 3.2 mPa)	255 lb (116 kg)	1.5 in. tri-clamp	1.5 in. tri-clamp

Models	Motor Rating	Lower Displacement	Flow Rate at 20 cpm	Maximum Fluid Working Pressure	Pump Weight	Fluid Inlet Connection	Fluid Outlet Connection
Yx44xx	5 HP (3.73 kW) 5.7 kVA 380–480 Vac 3 phase 50/60 Hz	3000cc	15.9 gpm (60 lpm)	400 psi (28 bar, 2.8 mPa)	256 lb (116 kg)	1.5 in. tri-clamp	1.5 in. tri-clamp
Yx33xx	5 HP (3.73 kW) 5.7 kVA 380–480 Vac 3 phase 50/60 Hz	4000cc	21.1 gpm (80 lpm)	300 psi (20.7 bar, 2.0 mPa)	258 lb (117 kg)	1.5 in. tri-clamp	1.5 in. tri-clamp
Recommended Maximum Continuous Cycle Rate			20 cpm				
Sound Data†			Less than 80 dB(A)				
Ambient Temperature Range			32–104°F (0–40°C)				
Maximum fluid temperature			150° F (66°C)				
Floor stand weight❖			65 lb (29.5 kg)				
Wall mount weight ❖			20 lb (9.1 kg)				
Oil capacity			2.0 quarts (1.9 liters)				
Oil specification			Graco Part Number 20A933 ISO 460 silicone-free high-pressure synthetic gear oil				
Wetted Parts			See lower manual. Find your lower part number in the <b>Pump Matrix</b> , page 19.				

❖ Add to the pump weight to determine total weight.

† Sound data measured 1 meter from a 5 HP motor with a 20 cpm flow rate.

# California Proposition 65

## CALIFORNIA RESIDENTS

 **WARNING:** Cancer and reproductive harm. – [www.P65warnings.ca.gov](http://www.P65warnings.ca.gov).

# Graco Standard Warranty

Graco warrants all equipment referenced in this document which is manufactured by Graco and bearing its name to be free from defects in material and workmanship on the date of sale to the original purchaser for use. With the exception of any special, extended, or limited warranty published by Graco, Graco will, for a period of twelve months from the date of sale, repair or replace any part of the equipment determined by Graco to be defective. This warranty applies only when the equipment is installed, operated and maintained in accordance with Graco's written recommendations.

This warranty does not cover, and Graco shall not be liable for general wear and tear, or any malfunction, damage or wear caused by faulty installation, misapplication, abrasion, corrosion, inadequate or improper maintenance, negligence, accident, tampering, or substitution of non-Graco component parts. Nor shall Graco be liable for malfunction, damage or wear caused by the incompatibility of Graco equipment with structures, accessories, equipment or materials not supplied by Graco, or the improper design, manufacture, installation, operation or maintenance of structures, accessories, equipment or materials not supplied by Graco.

This warranty is conditioned upon the prepaid return of the equipment claimed to be defective to an authorized Graco distributor for verification of the claimed defect. If the claimed defect is verified, Graco will repair or replace free of charge any defective parts. The equipment will be returned to the original purchaser transportation prepaid. If inspection of the equipment does not disclose any defect in material or workmanship, repairs will be made at a reasonable charge, which charges may include the costs of parts, labor, and transportation.

**THIS WARRANTY IS EXCLUSIVE, AND IS IN LIEU OF ANY OTHER WARRANTIES, EXPRESS OR IMPLIED, INCLUDING BUT NOT LIMITED TO WARRANTY OF MERCHANTABILITY OR WARRANTY OF FITNESS FOR A PARTICULAR PURPOSE.**

Graco's sole obligation and buyer's sole remedy for any breach of warranty shall be as set forth above. The buyer agrees that no other remedy (including, but not limited to, incidental or consequential damages for lost profits, lost sales, injury to person or property, or any other incidental or consequential loss) shall be available. Any action for breach of warranty must be brought within two (2) years of the date of sale.

**GRACO MAKES NO WARRANTY, AND DISCLAIMS ALL IMPLIED WARRANTIES OF MERCHANTABILITY AND FITNESS FOR A PARTICULAR PURPOSE, IN CONNECTION WITH ACCESSORIES, EQUIPMENT, MATERIALS OR COMPONENTS SOLD BUT NOT MANUFACTURED BY GRACO.** These items sold, but not manufactured by Graco (such as electric motors, switches, hose, etc.), are subject to the warranty, if any, of their manufacturer. Graco will provide purchaser with reasonable assistance in making any claim for breach of these warranties.

In no event will Graco be liable for indirect, incidental, special or consequential damages resulting from Graco supplying equipment hereunder, or the furnishing, performance, or use of any products or other goods sold hereto, whether due to a breach of contract, breach of warranty, the negligence of Graco, or otherwise.

## **FOR GRACO CANADA CUSTOMERS**

The Parties acknowledge that they have required that the present document, as well as all documents, notices and legal proceedings entered into, given or instituted pursuant hereto or relating directly or indirectly hereto, be drawn up in English. Les parties reconnaissent avoir convenu que la rédaction du présente document sera en Anglais, ainsi que tous documents, avis et procédures judiciaires exécutés, donnés ou intentés, à la suite de ou en rapport, directement ou indirectement, avec les procédures concernées.

# Graco Information

For the latest information about Graco products, visit [www.graco.com](http://www.graco.com).

For patent information, see [www.graco.com/patents](http://www.graco.com/patents).

**TO PLACE AN ORDER**, contact your Graco distributor or call to identify the nearest distributor.

**Toll Free Phone Number:** 1-800-328-0211

*All written and visual data contained in this document reflects the latest product information available at the time of publication.  
Graco reserves the right to make changes at any time without notice.*

Original instructions. This manual contains English. MM 3A7828

**Graco Headquarters:** Minneapolis

**International Offices:** Belgium, China, Japan, Korea

**GRACO INC. AND SUBSIDIARIES • P.O. BOX 1441 • MINNEAPOLIS MN 55440-1441 • USA**  
**Copyright 2022, Graco Inc. All Graco manufacturing locations are registered to ISO 9001.**

[www.graco.com](http://www.graco.com)  
Revision C, November 2024